

# Green Roofs

## For Your Home

### Want lower heating bills?

A green roof is completely or partially covered with vegetation in a growing medium planted over several layers of waterproof membrane, root barrier, and a drainage board. A green roof can absorb up to half of the rainwater and greatly increase the insulation value of your roof.

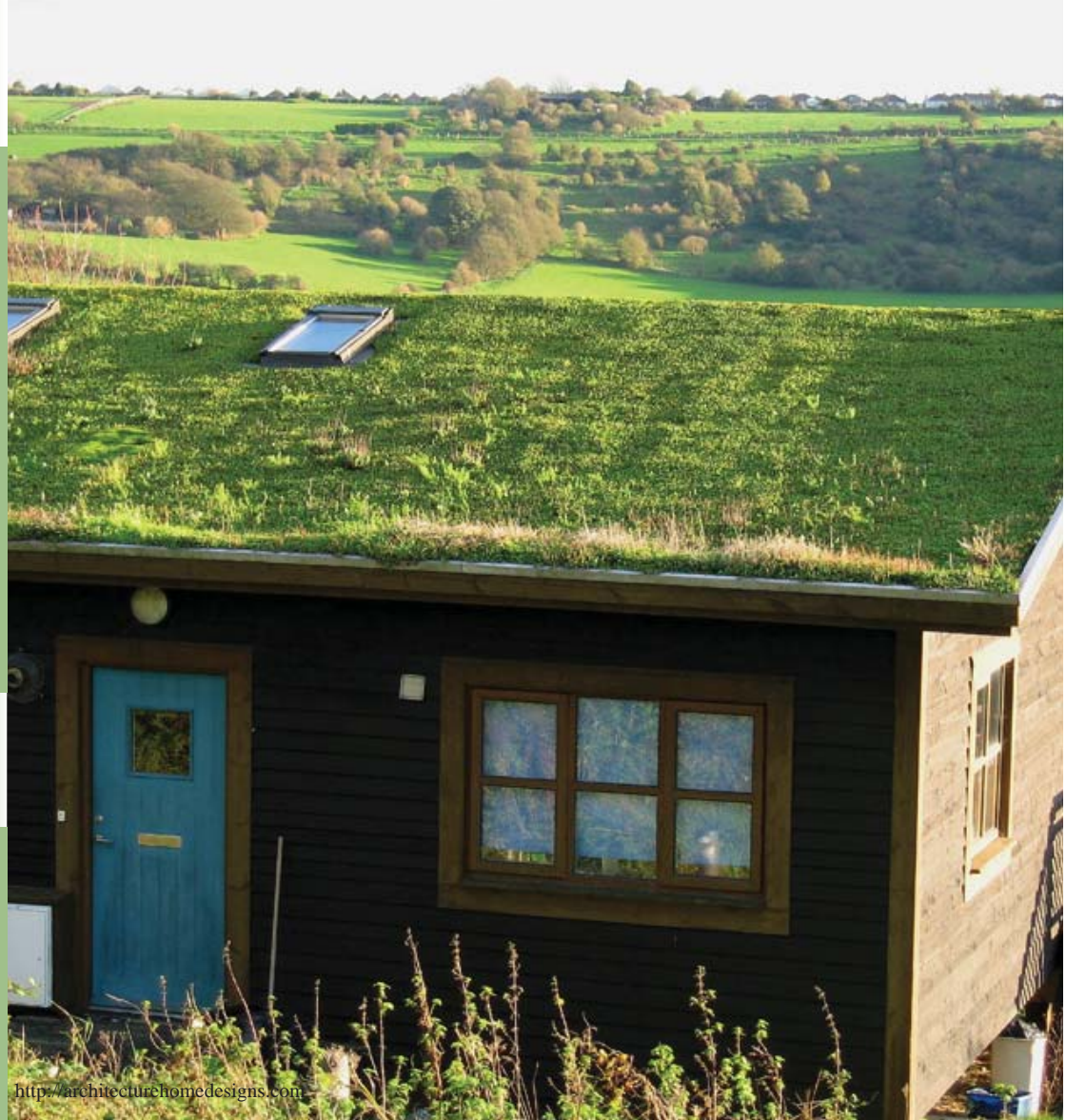

<http://architecturehomedesigns.com>

A green roof is completely or partially covered with vegetation in a growing medium planted over a waterproof membrane, root barrier, and a drainage board. There are two basic types of green roofs, extensive and intensive. An extensive roof has a layer of growing medium that is six inches or less. Extensive roofs can support the growth of grasses and some small shrubs. An intensive roof has a six to twenty four inch layer of growing medium. Intensive roofs can support larger shrubs and even trees. A green roof can absorb up to half of the rainwater that falls on it and greatly increase the insulation value of your roof.

### **Cold Climate Considerations:**

See following page for list of specific plants that will survive on a Fairbanks green roof.

### **Steps:**

The following steps outline the basic elements of a modern green roof. Every green roof installation is unique depending on the building on which it is to be used. It is essential that you consult a professional for more detailed and site specific information before building or adding a green roof.

1. Consult an engineer to determine the proper structural adjustments needed for the building to safely support the substantial extra weight of a green roof. Only after your structure has been determined to support the extra weight should you begin any installation of the green roof. To ensure the green roof is installed properly, hire a roofing company that is familiar with installing these systems. Attempting to install a green roof your self my negatively impact your homeowners insurance policy.

### **Here are the Steps the installer will take to install a green roof:**

2. Install a vapor control barrier on top of your roof structure.
3. Then install the insulation.
4. Install a waterproof membrane such as 60 mil EPDM rubber membrane. This can also act as the root barrier.
5. Install a drainage layer such as a drain board.
6. Install a moisture retention mat on top of the drain board. This helps plant growth by retaining water and making it easily available for plant use.
7. Lay down the growing medium. There are several options of growing medium: inorganic and organic, as well as engineered soils.
8. Plant selected plants.
9. Water the plants until they are established and during dry periods if so desired.

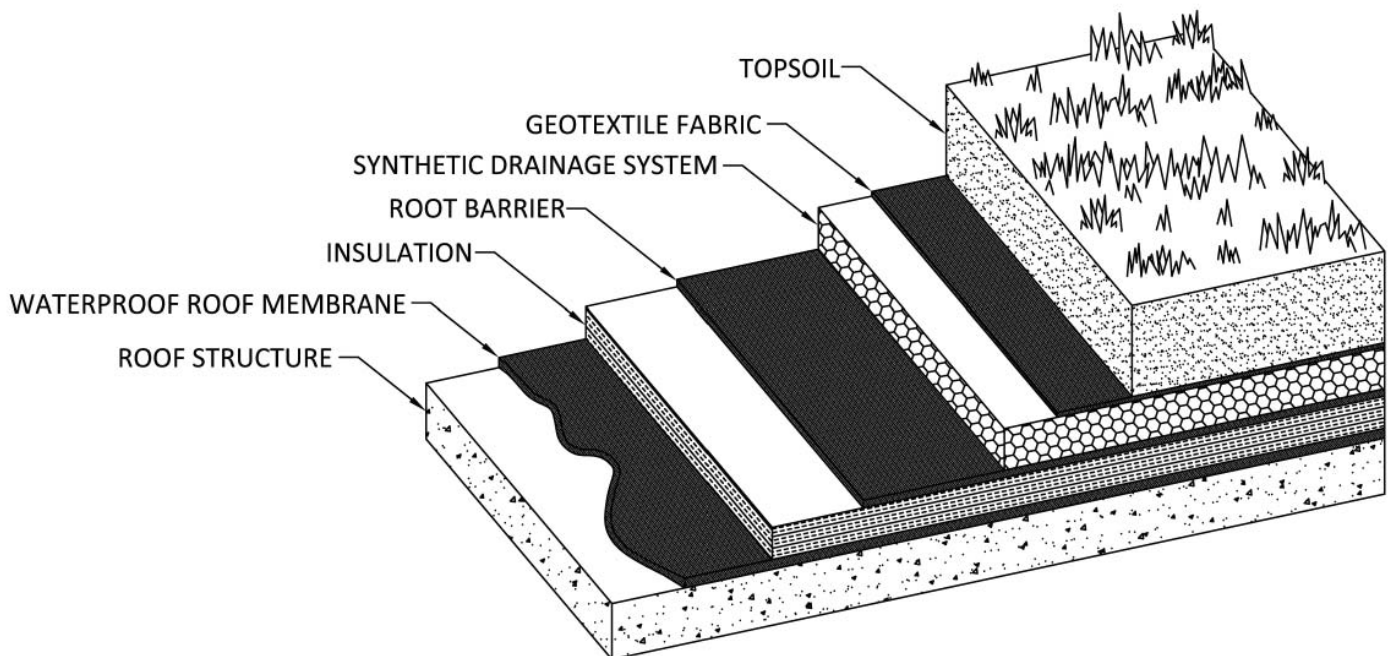

Below is the list of plants that were planted on the south green roof of the Cold Climate Housing Research Center in 2007. They have since naturalized, so not all species are currently represented in the bed. Take into account the amount of sun your roof gets when selecting plants for your green roof.

Plant Name	Latin Name
Nortran Tufted Hairgrass	<i>Deschampsia cespitosa</i>
Alyeska Polargrass	<i>Arctagrostis latifolia</i>
Tilesius' Wormwood	<i>Artemisia tilesii</i>
Tundra Bluegrass	<i>Poa glauca cv. Tundra</i>
Arctared Fescue	<i>Festuca rubra</i>
Mayweed	<i>Tripleurospermum</i>
Tall Jacob's Ladder	<i>Polemonium acutiflorum</i>
Arctic Goldenrod	<i>Solidago multiradiata var. arctica</i>
Nootka Lupine	<i>Lupinus nootkatensis</i>
Alpine Sweetvetch	<i>Hedysarum alpinum</i>
Wainwright Wheatgrass	<i>Elymus trachycaulus</i>
Sourdough Bluejoint Reedgrass	<i>Calamagrostis canadensis</i>



**Cost Estimate:**

- According to Green Roofs for Healthy Cities (see below for reference) green roofs cost \$15 to \$25 per sq ft. The green roof on the CCHRC building cost about \$19 per square foot in 2006. These cost estimates are for professional installation.

**Time Estimate:**

- This project could take five days to over a week to complete.

**Pros:**

- Reduces water runoff
- Filters water runoff
- Sound insulation
- Heat insulation
- Aesthetically pleasing
- Increases property value
- Creates habitat for birds and butterflies
- Can have a much longer lifespan than a traditional roofs
- Gardening without having to worry about moose etc.

**Cons:**

- High initial cost
- Possible insurance issues if installed incorrectly.
- Extensive green roofs can weigh ten to fifteen pounds per square foot when fully saturated
- Some buildings can't be retrofitted because they can't support the extra weight.
- Homeowner would need assistance to construct.

For more information about the Green Infrastructure Project please visit: [www.cchrc.org/green-infrastructure](http://www.cchrc.org/green-infrastructure)

**Sources:**

Cold Climate Housing Research Center, Green Roof website

<http://cchrc.org/green-roof>

Green Roofs for Healthy Cities website

<http://greenroofs.org>

Green Roof Plants: A Resource and Planting Guide, by Edmund C. Snodgrass and Lucie L. Snodgrass, 2006 from Timber Press, Portland, OR.

Living Roofs website

<http://livingroofs.org>

Low Impact Development Center, Inc., Green Roof

[www.lid-stormwater.net/greenroofs\\_home.htm](http://www.lid-stormwater.net/greenroofs_home.htm)



COLD CLIMATE HOUSING RESEARCH CENTER  
**CCHRC**



FAIRBANKS SOIL & WATER  
CONSERVATION DISTRICT

**GW Scientific**